



# PM-100D

UHF Wireless Monitoring System



 100% recycled paper  
100% papier recyclé

Installation and Operation

# Contents

01 Safety Operation and Notice .....	P 3
02 System Performance Feature .....	P 4
03 Packing List .....	P 5
04 Transmitter Front Panel Function Introduction .....	P 6
05 Transmitter Rear Panel Function Introduction .....	P 7
06 Receiver Function Introduction .....	P 8
Receiver display overview .....	P 10
07 Receiver Battery Installation .....	P 11
08 System Installation and Connection .....	P 12
System installation .....	P 12
System connection .....	P 12
09 System Equipment Connection Diagram .....	P 14
10 System Troubleshooting .....	P 15
PM-100D Stereo Transmitter .....	P 15
PM-100DR Stereo Mini Receiver .....	P 16
11 Technical Specification .....	P 17

Thank you for choosing a RELACART professional wireless microphone system. You have joined thousands of other satisfied customers. Our years of professional experience of design and manufacturing to ensure our products' quality, performance and reliability.

## 01 Safety Operation and Notice

1. Please read instructions for safety operation carefully before installation and operation. Please save your safety operation guide for future reference.
2. Do not scratch, bend, twist, stretch or heat the power cord as this may cause damage to the power cord, resulting in a fire or electric shock.
3. Do not open the device shell, otherwise it may cause electric shock. If you need to repair, maintain or repair, please contact your local agent.
4. Do not touch the power plug with wet hands as this may cause a fire or electric shock.
5. Do not attempt to modify this device. Failure to do so may result in personal injury or product malfunction.
6. Do not use this equipment near water.
7. If the power cord is damaged (such as a broken wire or bare core), obtain replacement parts from your dealer. Continued use of the equipment with a damaged power cord may result in fire or electric shock.
8. To move the device he power, unplug the power cord, and unplug all connecting cables as this may damage the cable, resulting in a fire or electric shock.
9. Before cleaning the device, unplug the power cord and unplug all connecting cables. Please clean it with a dry soft cloth.
10. If the device is not in use for a long time, turn off the power, it is best to unplug the socket.
11. With the power plug and appliance coupler as the disconnecting device, it should be kept easy to operate.
12. For the safe use of the equipment and adequate ventilation, the minimum clearance around the equipment should be maintained at a distance of 5 cm or more.
13. DO NOT cover the Ventilation holes, such as: newspaper / fabric / curtains and other items.
14. Equipment should not be placed on a bare flame source, such as: lit candles.
15. Battery should not be exposed to sunshine, roasted or other high temperature overheating environment.
16. Do not throw the waste battery, please put in the designated bins.
17. Water protection rating: IPX0
18. The device can be used normally in tropical / temperate climates.
19. This product is only suitable for safe use at the altitude of 2000m and below.
20. This symbol "⚡" indicates that dangerous voltage constituting a risk of electric shock is present within this unit.
21. All Relacart products will be afforded one year free maintenance except for man-made damage, such as:
  - the device is damaged by man-made factors.
  - the device is damaged by improper operation.
  - some components are damaged or loss after the self-disassembly.

## 02 System Performance Feature

PM-100D is a simple, flexible and reliable wireless personal monitoring system that sets a new standard and brings greater freedom for outdoor broadcasting, stage performances, instrument playing, multi-person podcasting and other scenarios, easy to use even no technical experience. This convenient and durable system provides prestigious Relacart sound quality and highly reliable professional-grade wireless technology. It replaces traditional complicated and heavy monitoring equipment with advanced electronic processing technology, eliminates the feedback generated by the monitoring equipment, and makes the performance reliable and perfect.

### Key Features:

- Metal 1/2 EIA standard 1U case.
- The housing of PM-100D receiver is made of light-weight and strong plastic materials.
- Exquisite and simple LCD multi-function display.
- The receiver uses the UHF frequency band, and the CPU controls diversity reception to reduce dead spots and ensure stable reception.
- The bandwidth is up to 32MHz, with 100 adjustable preset channels.
- Stereo and mono selection.
- With headphone monitoring output.
- With long transmission distance, it is suitable for various occasions.

## 03 Packing List

- ◆ Wireless receiver \*1
- ◆ Transmitter \* 1
- ◆ BNC Antenna \*1
- ◆ Power adapter \* 1
- ◆ 1.5V/AA battery \* 2
- ◆ Stereo line \* 2
- ◆ Rack mount kit (screw) \* 1 set
- ◆ Installation and operation \* 1

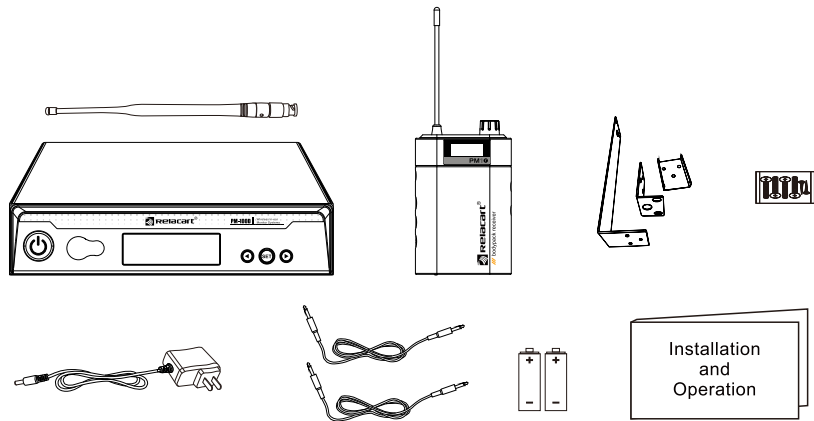

## 04 Transmitter Front Panel Function Introduction

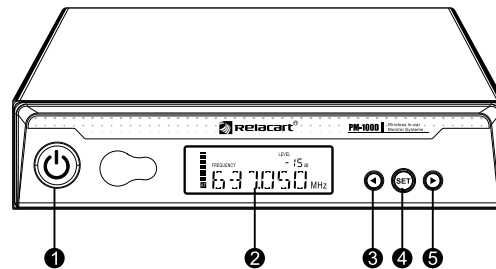

- ❶ Power switch (with indicator light).
- ❷ LCD screen: Display the current working status and other information.
- ❸ "◀" Operation button: Select the channel upward
- ❹ "SET" setting button: Long press to enter the channel setting or short press to confirm the setting.
- ❺ "▶" Operation buttons: Select the channel downward.

## 05 Transmitter Rear Panel Function Introduction

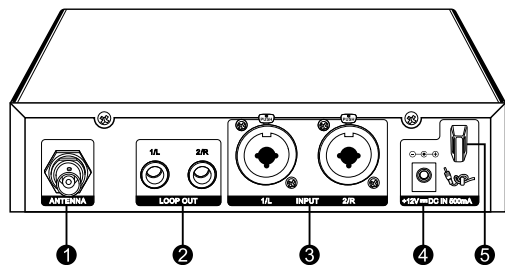

- 1 BNC antenna interface: For connecting the included antenna.
- 2  $\phi 6.3$  mm unbalanced mixed output jack: Stereo output.
- 3 XLR-3/6.3mm combo jack: Connect to balanced or unbalanced output. Any connector can be used for mono input. Accept 6.3mm plugs or XLR plugs.
- 4 DC IN socket: Connect to DC 12V external power adapter.
- 5 Anti-pull device: Used to fix the connecting cable of the external power adapter DC 12V.

## 06 Receiver Function Introduction

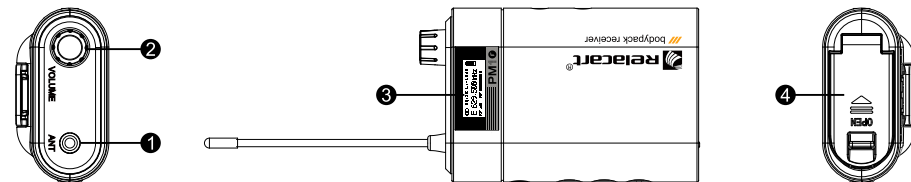

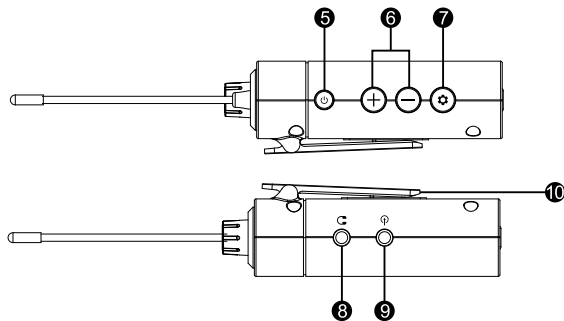

- 1 External antenna: 1/4 wavelength antenna.
- 2 Volume potentiometer: The volume potentiometer can adjust the level. The output level can be adjusted within the range of -30dB to 0dB, and can be adjusted by the step of 1dB.
- 3 OLED display: Display information such as frequency, channel, mixing mode or current battery level.
- 4 Battery Compartment: Open the battery door by sliding the switch and insert 2 fresh 1.5V AA batteries. (Alkaline type is recommended. Please remember to replace both batteries.)  
Warn: Observe correct polarity as marked inside the battery compartment to avoid damage to the internal electric parts.



- ⑤ Power switch: Long press for two seconds to turn on and off the power of the device.
- ⑥ “+/-” button: Used to scroll through the menu items to change the preset value, used with the “SET” setting button.
- ⑦ “SET” button:
  - Press this key to display the channel.
  - Long press this button to enter the menu setting mode (flashing), and short press to call each menu item in turn to select or confirm the menu setting. When the selected menu item is flashing, it can be used with the “+/-” button to change the setting value.
- ⑧ 3.5mm headphone port: Used to connect headphone equipment for sound monitoring
- ⑨ 3.5mm line out port: Used for audio output or connecting earphones.
- ⑩ Belt Clip: Secures the receiver around the user’s belt or on objects such as guitar straps.

## Receiver display overview



- ① Audio mode: When mono is selected, it is displayed as “”; When stereo is selected, it is displayed as “”.
- ② Squelch Threshold: Displays the parameters for adjusting the squelch threshold.
- ③ Adjust the volume level, a total of 30dB adjustable.
- ④ Battery status: 4 bars are fully charged, please replace with new ones in time when there is one bar left.
- ⑤ Band icon indication.
- ⑥ Displays the set receiving frequency or channel.
- ⑦ “RF” radio signal level: The strength of the received radio signal.
- ⑧ “AF” audio frequency: Indicates the audio input level of the transmitter.

## 07 Receiver Battery Installation

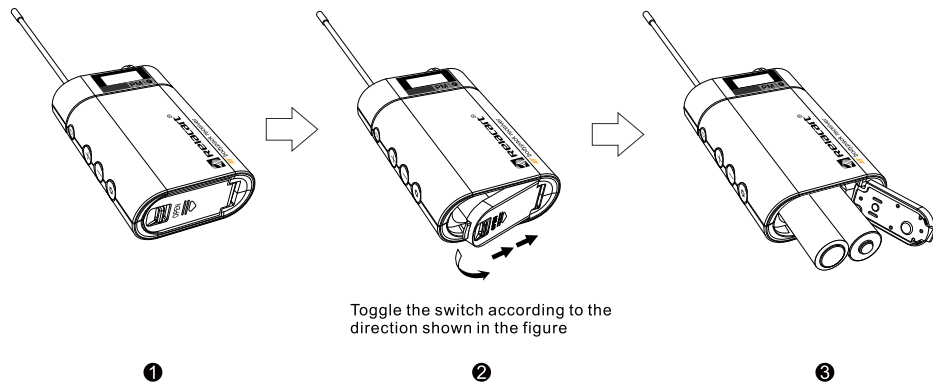

Toggle the switch according to the direction shown in the figure

## 08 System Installation and Connection

### System installation

1. In order to achieve the best operation of the equipment, the height of the receiver should be higher than 1 meter from the bottom and at least 1 meter from the wall surface.
2. Keep the antenna away from interference sources, such as computer equipment, digital equipment, televisions and cars, and also away from large-area metal objects.
3. Install the antenna on the antenna connector on the rear panel, and pull the antenna to a position at a 45° angle to the vertical.
4. Minimize obstacles as much as possible between the location of the receiver and the place where the transmitter is used.
5. When two transmitters are used at the same time, the distance between the transmitter and the receiver must be at least 2 meters.

### System connection

1. Connect the output end of the DC12V/500mA DC output power supply to the transmitter DC power input socket. To prevent the DC plug from accidentally detaching, first pass the wire through the fixing hole and then tighten it. (Note: The input voltage of the AC power adapter must be selected to meet the power supply specification range of the area of use.)
2. There are two types of audio jacks on the rear panel of the transmitter, namely  $\Phi 6.3\text{mm}$  balanced output socket and XLR-3/6.3mm combined balanced input jack.
  - ① Use a suitable cable to connect the output of an external device (such as a mixer or a second PM-100D TX) to the XLR-3/6.3mm combined balanced input jack.
  - ② Use a suitable cable to connect the input end of an external device (such as a mixer or a second PM-100D TX) to the  $\Phi 6.3\text{mm}$  balanced output jack.(Note: After the signals of the input jacks INPUT 1/L and INPUT 2/R are separated, they continue to be transmitted to the output jacks LOOP OUT 1/L and LOOP OUT 2/R. Therefore, you can only transmit Use the output jack when the machine is switched on. )

## 09 System Equipment Connection Diagram

### 3. Set the appropriate audio input level

The intensity of the audio input signal will be displayed on the AF level meter on the OLED display panel, and the intensity of the input audio signal will be adjusted appropriately. Therefore, the input intensity must be adjusted appropriately to obtain the best signal-to-noise ratio and dynamic range, and to avoid signal distortion.

### 4. Headphone connection

Insert the monitor headphone connection plug into the 3.5mm headphone stereo socket, you can also connect general headphones or connect the output end to the audio input of other audio equipment. Note: The headphone output socket is a stereo output. Note that the connected plug must be a stereo plug. If it is a mono headphone plug, one side of the output may be short-circuited and the headphone output circuit on the other side may be burned.

### 5. Multi-system mixed group connection mode

Some performers need to hear their own instruments and the mixed band signal. With the help of this device, each performance group can hear the effect of each combination or their independent performance. In the attached picture, a group is sent from the mixer. The mixed signal of the whole band is sent to the INPUT 1/L and INPUT 2/R input terminals of the first group of transmitters (PM-100D), and then another group of independent performance signals is sent from the mixer to the second group of transmitter, send the different combinations of signals to the corresponding transmitters via mixer. This connection can be used to operate all transmitters, and create mixer solos for individual performers through the mixer's aux outputs. Performers can hear different combinations by receiving signals from different transmitters.

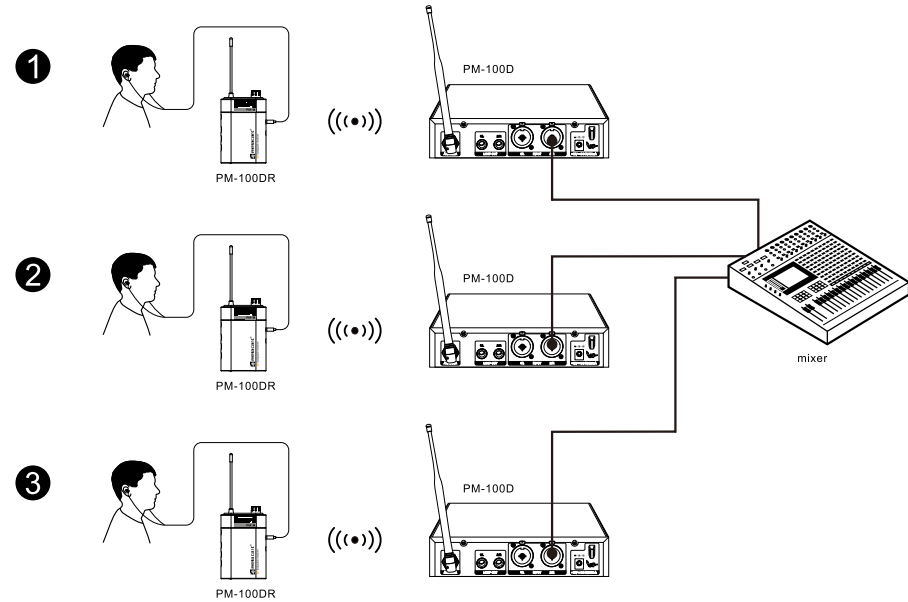



## 10 System Troubleshooting

### PM-100D Stereo Transmitter

Symptom	Cause of issue	Solution
Turn on the power switch, but it cannot be turned on, and the power indicator light is off	The power cord is not plugged into the power outlet	Correctly connect the power cord and plug provided with the host, and power on the host
Sound receiving distance is too short	The wireless receiving antenna is not connected or not connected properly	Connect the antenna correctly
	There are obstacles in the transmission space	Move or avoid obstacles
No Stereo audio modulation	Stereo audio modulation menu set to mono modulation	Stereo Audio Modulation menu set to Stereo Modulation
	Source audio signal output is not stereo	Audio signal with stereo output

### PM-100DR Stereo Mini Receiver

Symptom	Cause of issue	Solution
Can not boot	Battery dead	Replacement battery
	The positive and negative poles of the battery are reversed	Connect the battery correctly
Headphones have no sound	Whether it works at the normal use distance	Use the Receiver at an appropriate distance
	Volume potentiometer is not turned on	Turn on the volume potentiometer
	Does not correspond to transmitter frequency	Adjust the receiver frequency to correspond to the transmitter frequency
No stereo audio	Stereo audio switch to mono	Stereo audio switch is set to stereo
	Transmitter without stereo audio modulation	Check transmitter

# 11 Technical Specification

## PM-100D Stereo Transmitter

Main Frame Size:	EIA standard 1/2 U
Carrier Frequency Range:	554MHz ~ 936 MHz
Channels:	Single Channel
Modulation Method:	Integrated mode
T.H.D:	<0.9% @ 1KHz
Frequency Bandwidth:	32MHz
Frequency Response:	20Hz ~ 20KHz ± 3dB
Output Power:	50mW
Current Consumption:	160mA
Power Supply Mode:	DC 12V
Audio Output:	Φ6.3mm balanced socket x2
Audio Input:	Line level x 2, XLR and φ6.3mm co composite socket
Dimension (mm):	205 (W) x 43 (H) x 206 (D)
Weight:	Approximately 1kg

## PM-100DR Stereo Mini Receiver

Receiving Method:	Antenna reception
Carrier Frequency Range:	554MHz ~ 936 MHz
Channels:	Single Channel
Modulation Method:	Integrated mode
T.H.D:	<0.9% @ 1KHz
Stereo Separation:	≥65dB, at 1KHz
Frequency Response:	20Hz ~ 20KHz ± 3dB
Battery:	AA X 2
Current Consumption:	140mA (Typical)
Battery Current/life:	≥ 8 hours
Working Distance:	100 meters in general (In open space)
Output Socket:	Φ3.5mm stereo headphone socket
Output Power:	2x40mW at 1KHz (T.H.D.: 0.03%)
Dimension (mm):	198 (H) x 52.5 (W) x 28 (D)
Weight:	Approximately 55g (w/o battery)